

Spare Parts List
Ersatzteilliste
Liste de pièces détachées
Lista de piezas de repuesto

2010-08



MS-20 C
(USA)

MS-22 C
(USA)

DOLMAR



A member of the *Makita* Group

995700252 (D, GB, F, E)

MS-20 C (USA) , MS-22 C (USA)

1

Hauptrohr, Griff, Schutzhaube, Vergaser, Luftfilter
Pipe, handle, protector, carburetor, air cleaner
Tubo, poignée, capot de protection, carburateur, filtre à air
Tubo, mango, cubierta protectora, carburador, filtro de aire

DOLMAR
A member of the *Hakita* Group

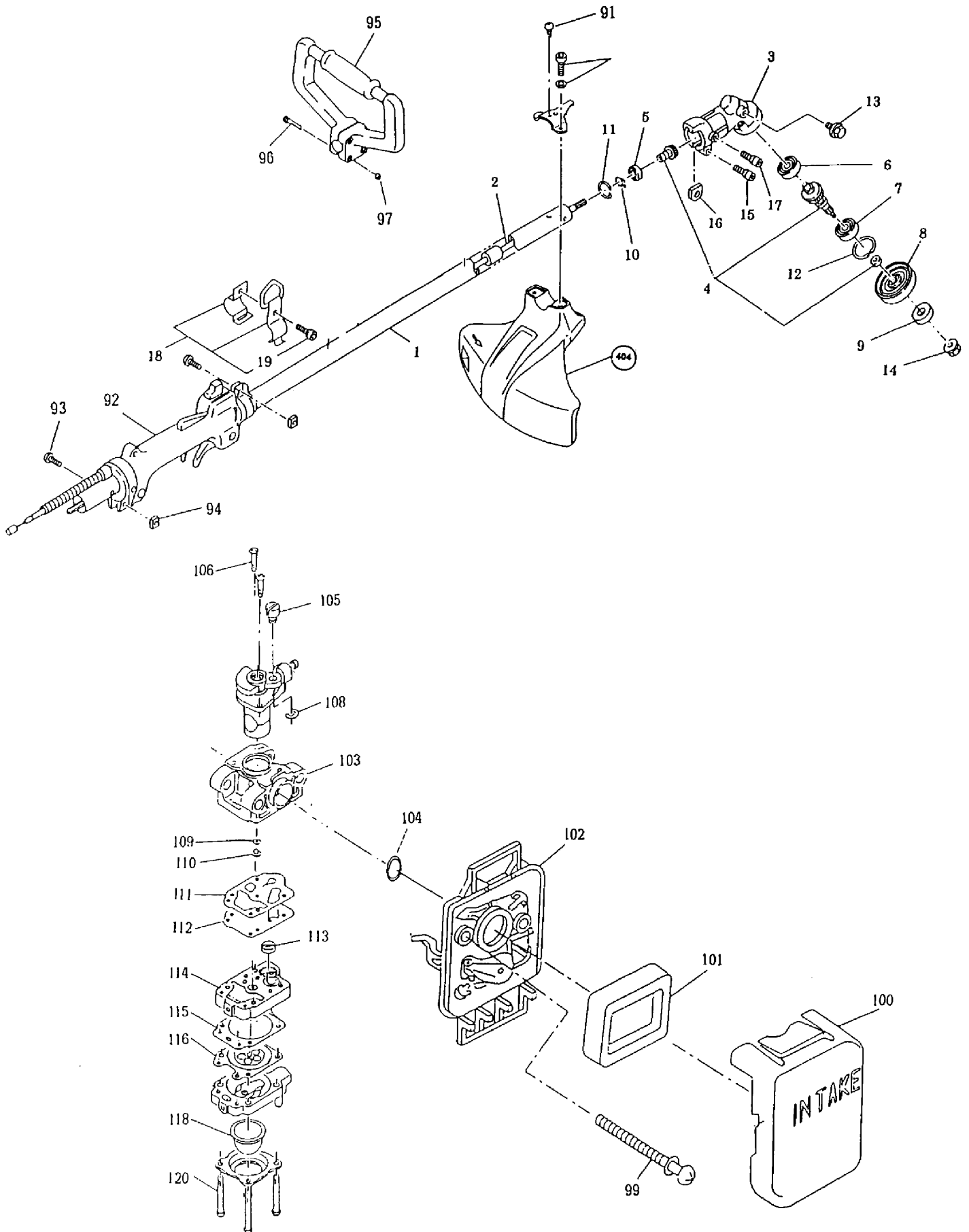

MS-20 C (USA) , MS-22 C (USA)

1

Hauptrohr, Griff, Schutzhaube, Vergaser, Luftfilter
 Pipe, handle, protector, carburetor, air cleaner
 Tube, poignée, capot de protection, carburateur, filtre à air
 Tubo, mango, cubierta protectora, carburador, filtro de aire

DOLMAR

 A member of the *Makita* Group

Seite / Page	Pos.	MS-20 C (USA)	Teil-Nr. Part No. No. de pièce No. de pieza	Hinweise Notes Renseign. Nota	Bezeichnung	Spezifikation Specification	Description	Désignation	Denominación
1	1	1	374 101 000		SCHAFTROHR KPL.		MAIN PIPE ASSY.	TUBE PRINCIPAL CPL.	TUBO PRINCIPAL CPL.
1	2	1	367 150 630		WELLE		SHAFT	ARBRE	ÁRBOL
1	3	1	381 300 400		GETRIEBEGEHÄUSE KPL.		GEAR CASE ASSY	CARTER D'ENGRENAGES CPL.	CAJA DE ENGRANAJES CPL.
1	4	1	367 300 300		WINKELANTRIEB		CUTTER SHAFT SET	ENGRENAGE	ENGRANAJE
1	5	1	381 250 030		KUGELLAGER	#609ZZ	BALL BEARING	ROULEMENT A BILLES	RODAMIENTO DE BOLAS
1	6	1	367 006 999		KUGELLAGER	626ZZ	BALL BEARING	ROULEMENT A BILLES	RODAMIENTO DE BOLAS
1	7	1	388 010 991		KUGELLAGER	6000DDU	BALL BEARING	ROULEMENT A BILLES	RODAMIENTO DE BOLAS
1	8	1	381 850 010		AUFNAHMESCHEIBE	Z6	RECEIVE WASHER	DISQUE DE SUPPORT	DISCO DE SUJECIÓN
1	9	1	381 300 401		SCHEIBE		WASHER	RONDELLE	ARANDELA
1	10	1	381 150 800		SICHERUNGSRING		OUTER SNAP RING	CIRCLIP	ANILLO SEGURIDAD
1	11	1	381 142 400		SICHERUNGSRING		INNER SNAP RING	CIRCLIP	ANILLO SEGURIDAD
1	12	1	381 142 600		SICHERUNGSRING		INNER SNAP RING	CIRCLIP INTERIEUR	ARANDELA DE SEGURIDAD INTERIOR
1	13	1	367 301 101		BOLZEN	M6X9	BOLT	BOULON	BULÓN
1	14	1	381 300 402		MUTTER	M8	NUT	ECROU	TUERCA
1	15	1	367 905 989		SCHRAUBE	M5X25	S. H. BOLT	VIS	TORNILLO
1	16	1	381 150 140		DICHTUNG		GASKET	JOINT	JUNTA
1	17	1	367 905 990		SCHRAUBE	M5X12 W/SW	S. H. BOLT	VIS	TORNILLO
1	18	1	381 700 200		TRAGEGURTAUFNAHME KPL.		HANGER ASS'Y	ATTACHE DE BRETTELLE COMPL.	SUJECIÓN COMPL.
1	19	1	374 905 985		INNEN-6KT-SCHRAUBE	M5X14	SOCKET HEAD BOLT	VIS	TORNILLO
1	91	1	381 005 994		FIXIERSCHRAUBE		TAPPING SCREW	VIS	TORNILLO
1	92	1	374 500 700		BEDIENUNGSHANDGRIF KPL.	INC. 93,94	CONTROL LEVER ASS'Y	LEVIER DE RÉGLAGE, CPL.	BOTÓN DE MANDO, CPL.
1	93	2	374 906 988		SCHRAUBE	M6X20	SOCKET HEAD BOLT	VIS	TORNILLO
1	94	2	374 501 114		MUTTER		NUT	ECROU	TUERCA
1	95	1	374 450 000		GRIFF		HANDLE	POIGNÉE	MANGO
1	96	4	367 905 986		SCHRAUBE	M5X33	S. H. BOLT	VIS	TORNILLO
1	97	4	381 270 500		MUTTER	M5	NUT	ECROU	TUERCA
1	99	2	374 330 565		SCHRAUBE KPL. 5X65	M5x65	SCREW ASSY.	VIS CPL.	TORNILLO CPL.
1	100	1	374 300 403		LUFTFILTERDECKEL		AIR CLEANER COVER	COUVERCLE	TAPA
1	101	1	374 300 401		LUFTFILTER		AIR FILTER	FILTRE A AIR NYLON	FILTRO DE AIRE NYLON
1	102	1	374 300 402		LUFTFILTERGEHÄUSE		AIR CLEANER HOUSING	FOND A AIR	FONDO DE AIRE
1	103	1	374 600 500		VERGASER	INC. 105,106,108-120	CARBURETOR	CARBURATEUR	CARBURADOR
1	104	1	374 606 100		O-RING		O RING	BAGUE-JOINT	ANILLO DE GUARNICION
1	105	1	367 325 922		NOCKEN		SWIVEL	CAME	LEVA
1	106	2	388 600 803		ZYL.SCHRAUBE		SCREW	VIS CYLINDRIQUE	TORNILLO DE LA CULATA
1	108	1	381 600 512		SICHERUNGSSCHEIBE		SAFETY WASHER	RONDELLE SÉCURITÉ	ARANDELA SEGURIDAD
1	109	1	367 213 538		O-RING	2	O RING	ANNEAU TORIQUE	ANILLO OBTURADOR
1	110	1	374 600 202		DÜSE		JET	BUSE	CHICLÉ
1	111	1	381 600 103		DICHTUNG		GASKET	JOINT	JUNTA
1	112	1	367 168 575		PUMPENMEMBRANE		PUMP DIAPHRAGM	MEMBRANE DE POMPE	MEMBRANAS DE LA BOMBA
1	113	1	381 600 401		SIEB		INLET SCREEN	TAMIS	TAMIZ
1	114	1	374 604 613		PUMPENKÖRPER KPL.		PUMP BODY ASS'Y	POMPE CPL.	BOMBA CPL.

MS-20 C (USA) , MS-22 C (USA)

1

Hauptrohr, Griff, Schutzhaube, Vergaser, Luftfilter
Pipe, handle, protector, carburetor, air cleaner
Tubo, poignée, capot de protection, carburateur, filtre à air
Tubo, mango, cubierta protectora, carburador, filtro de aire

DOLMAR
A member of the *Hakita* Group

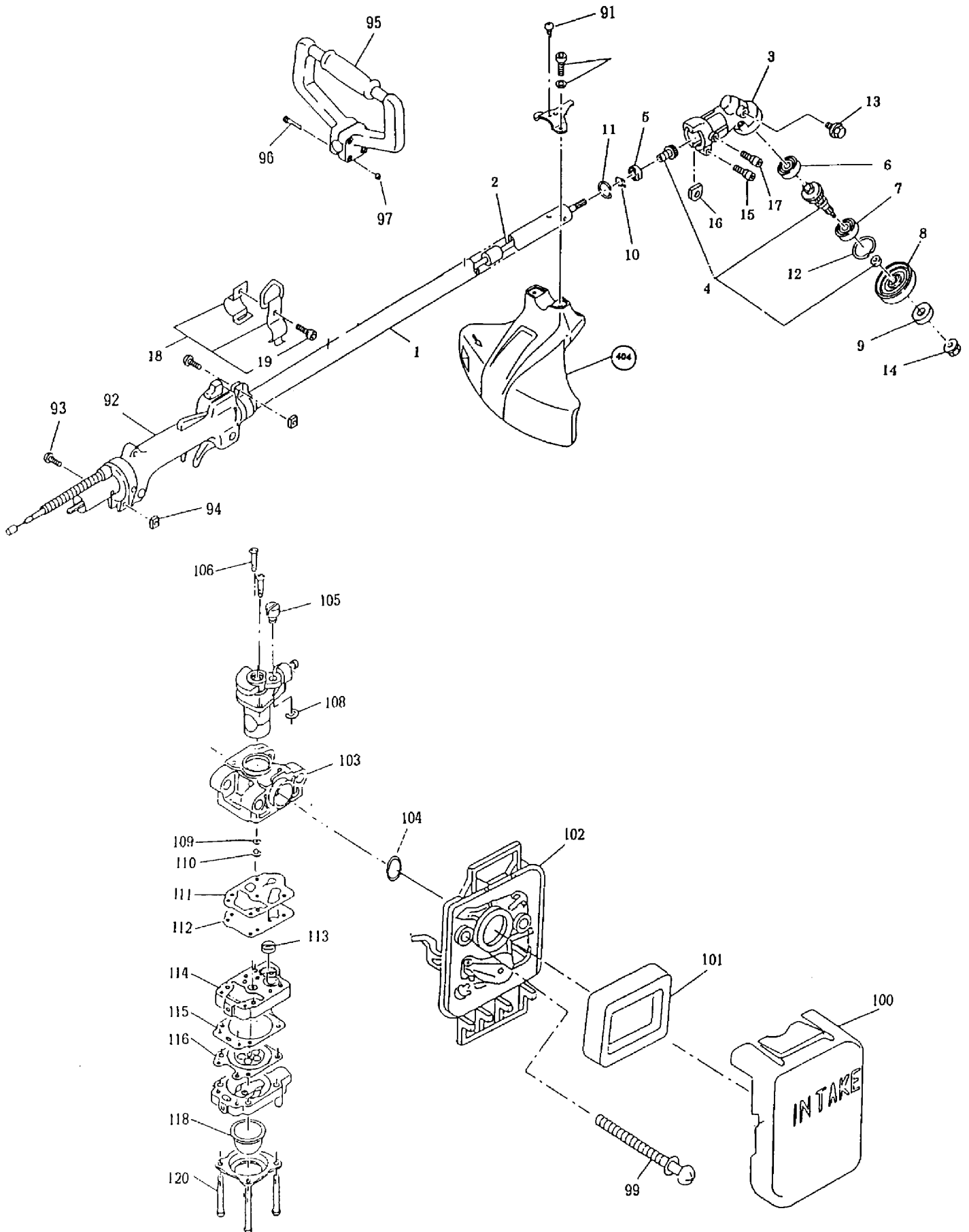

MS-20 C (USA) , MS-22 C (USA)

1

Hauptrohr, Griff, Schutzhaube, Vergaser, Luftfilter
 Pipe, handle, protector, carburetor, air cleaner
 Tube, poignée, capot de protection, carburateur, filtre à air
 Tubo, mango, cubierta protectora, carburador, filtro de aire

DOLMAR

 A member of the *Makita* Group

Seite / Page	Pos.	MS-20 C (USA)	Teil-Nr. Part No. No. de pièce No. de pieza	Hinweise Notes Renseign. Nota	Bezeichnung	Spezifikation Specification	Description	Désignation	Denominación
1	115	1	367 442 154		DICHTUNG		METERING DIAPHRAGM GASKET	JOINT	JUNTA
1	116	2	001 151 460		STEUERMEMBRANE		METERING DIAPHRAGM	MEMBRANE DE COMMANDE	MEMBRANAS DE MANDO
1	118	1	381 600 115		PRIMER PUMPE		PRIMER PUMP	POMPE PRIMER	BOMBA PRIMER
1	120	4	367 266 582		BLECHSCHRAUBE	3X24	TAPPING SCREW	VIS TARAUDEUSE	TORNILLO DE ROSCA CORTANTE
1	404	1	381 800 800		SCHUTZHAUBE FÜR NYLONKOPF		PROTECTION HOOD ASS'Y	CAPOT DE PROTECTION CPL.	CUBIERTA PROTECTORA CPL.
1	A03	1	381 224 263		FADENKOPF	ULTRA-AUTO-4	NYLON CUTTING HEAD	TETE A 2 FILS	CABEZA 2 CORT
1	A03 .1	1	381 224 350		ADAPTER		ADAPTOR, LEFT THREAD	ADAPTEUR GAUCHE	ADAPTADOR IZQUIERDA
1	A03 .2	2	381 224 330		FADENBUCHSE		THREAD BUSH	DOUILLE DE FIL	BUJE DE HILO
1	A03 .3	1	381 224 310		SPULE		SPOOL FOR LINE	BOUBINE DE FIL	BOBINA CON HILO
1	A03 .4	1	381 224 390		DECKEL		COVER	CAPOT	CUBIERTA
1	A03 .5	1	381 224 320		KNOPF		BUTTON	BOUCHON	BOTON

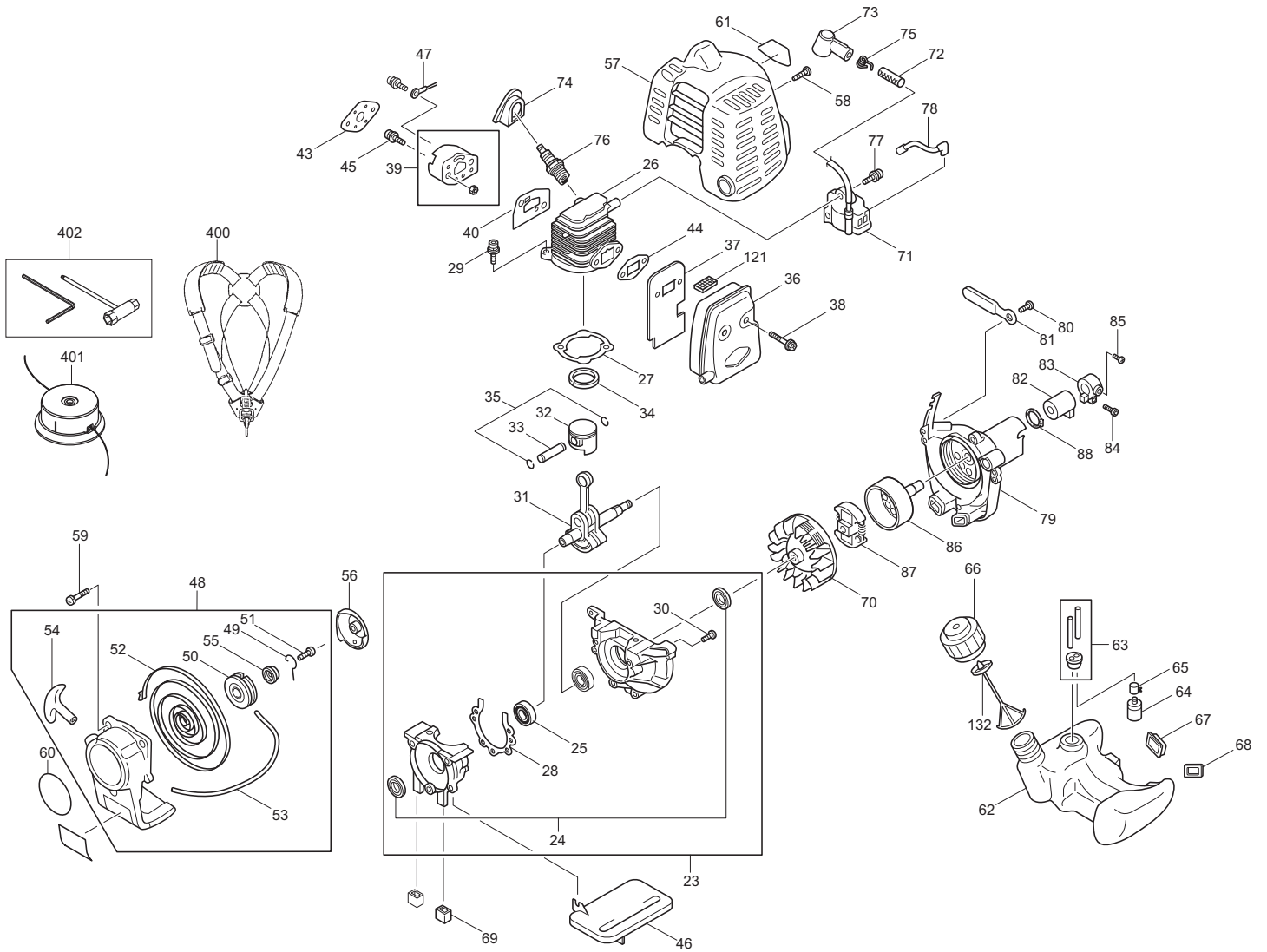

MS-20 C (USA) , MS-22 C (USA)

2

Motor, Anwerfvorrichtung, Kupplung, Kraftstofftank, Zubehör
 Engine, starter, clutch, fuel tank, accessories
 Moteur, dispositif de démarrage, embrayage, réservoir d'essence, accessoires
 Motor, dispositivo de arranque, embrague, depósito de combustible, accesorios



Seite / Page	Pos.	MS-20 C (USA)	Teil-Nr. Part No. No. de pièce No. de pieza	Hinweise Notes Renseign. Nota	Bezeichnung	Spezifikation Specification	Description	Désignation	Denominación
2	23	1	383 100 400		KURBELGEHÄUSE KPL.		CRANKCASE CPL.	CARTER-VILEBREQUI N CPL.	CÁRTER CIGÜEÑAL CPL.
2	24	2	374 010 998		RADIALDICHTUNG		OIL SEAL	JOINT RADIAL	JUNTA RADIAL
2	25	2	381 010 998		KUGELLAGER	6000	BALL BEARING	ROULEMENT Á BILLES	RODAMIENTO DE BOLAS
2	26	1	374 150 070		ZYLINDER		CYLINDER	CYLINDRE	CILÍNDRIO
2	27	1	382 150 030		DICHTUNG		CYLINDER GASKET	JOINT	JUNTA
2	28	1	318 150 040		DICHTUNG		CRANKCASE GASKET	JOINT	JUNTA
2	29	2	382 905 973		SCHRAUBE	M5X20 W/W&SW	SOCKET HEAD BOLT	VIS	TORNILLO
2	30	3	388 005 950		SCHRAUBE	M5X25	SCREW	VIS	TORNILLO
2	31	1	388 200 100		KURBELWELLE KPL.		CRANKSHAFT ASSY.	VILEBREQUIN CPL. CPL.	CIGÜEÑAL CPL.
2	32	1	381 250 080		KOLBEN		PISTON	PISTON	PISTÓN
2	33	1	367 250 050		KOLBENBOLZEN		PISTON PIN	AXE DE PISTON	BULÓN DEL PISTÓN
2	34	1	367 250 060		KOLBENRING		PISTON RING	SEGMENT DE PISTON	SEGMENT DE PISTON
2	35	2	388 508 997		SPRENGRING		CLIP	ANNEAU RESSORT	ANILLO ELÁSTICO
2	36	1	368 300 100		SCHALLDÄMPFER KPL.		EXHAUST MUFFLER	POT D' ÉCHAPPEMENT	SILENCIADOR
2	37	1	381 350 000		ABSCHIRMBLECH		MUFFLER INSULATOR	TÔLE DE DERIVATION	CHAPA DE DISIPACIÓN
2	38	2	367 905 952		SCHRAUBE	M5X40	SOCKET HEAD BOLT	VIS	TORNILLO
2	39	1	381 301 400		ZWISCHENFLANSCH		INSULATOR	BRIDE INTERMEDIAIRE	BRIDA INTERMEDIA
2	40	1	377 350 050		DICHTUNG F. ZWISCHENFLANSCH		INSULATOR GASKET	JOINT	JUNTA
2	44	1	377 350 020		DICHTUNG		GASKET (MUFFLER)	JOINT	JUNTA
2	45	2	388 005 950		SCHRAUBE	M5X25	SCREW	VIS	TORNILLO
2	46	1	383 350 010		PLATTE		PLATE	PLAQUE	PLANCHA
2	47	1	381 550 020		KABEL		WIRE	CÂBLE	CABLE
2	48	1	381 500 900		STARTVORRICHTUN G		REWIND STARTER	DISPOS. DE DÉMARRAGE	DISPOS. DE ARRANQUE
2	49	1	367 500 210		MITNEHMERBÜGEL		SWING ARM	ETRIER D'ENTRAÎNEMENT	BRAZO OSCILANTE
2	50	1	383 500 203		SEILTROMMEL		REEL	TAMBOUR DE CÂBLE	TAMBOR PARA CUERDA
2	51	1	367 266 585		BLECHSCHRAUBE	5X12	TAPPING SCREW	VIS TARAUEUSE	TORNILLO DE ROSCA CORTANTE
2	52	1	381 500 205		RÜCKHOLFEDER		SPIRAL SPRING	RESSORT DE RAPPEL	RESORTE RETENCION
2	53	1	388 501 602		ANWERFSEIL	Ø 3,5 x 850 mm	STARTER ROPE	CORDE DE LANCEUR	CUERDA DE ARRANQUE
2	54	1	388 500 402		GRIFF		HANDLE CPL.	POIGNÉE	EMPUÑADURA
2	55	1	367 500 211		AUFNAHME F. MITNEHMERBÜGEL		COLLAR	LOGEMENT POU ETRIER	ANILLO DE RETENCIÓN
2	56	1	367 550 000		STARTERRAD		PULLEY	ROUE DÉMARREUR	RUEDA DE ARRANQUE
2	57	1	381 550 120		ZYLINDERHAUBE		CYLINDER COVER	CAPOT DE CYLINDRE	TAPA PARA CYLINDRO
2	58	1	377 150 050		BLECHSCHRAUBE		TAPPING SCREW	VIS TARAUEUSE	TORNILLO DE ROSCA CORTANTE
2	59	3	367 360 425		SCHRAUBE KPL.	M4X25	SCREW ASS'Y	VIS CPL.	TORNILLO CPL.
2	43	1	374 350 040		DICHTUNG		CARBURETOR GASKET	JOINT	JUNTA
2	61	1	381 950 810		SCHILD	DOLMAR	TRADE MARK LABEL "DOLMAR"	PLAQUE	PLACA
2	62	1	382 650 000		KRAFTSTOFFTANK		FUEL TANK	RESERVOIR D'ESSENCE	DÉPÓSITO DE COMBUSTIBLE
2	63	1	374 113 995		SCHLAUCH KPL.		TUBE	TUBE	TUBO
2	64	1	320 163 447		BENZINFILTER		GASOLIN FILTER	FILTRE D'ESSENCE	FILTRO DE GASOLINA
2	65	1	382 650 170		SCHLAUCH		HOSE CLAMP	GAINÉ	TUBO

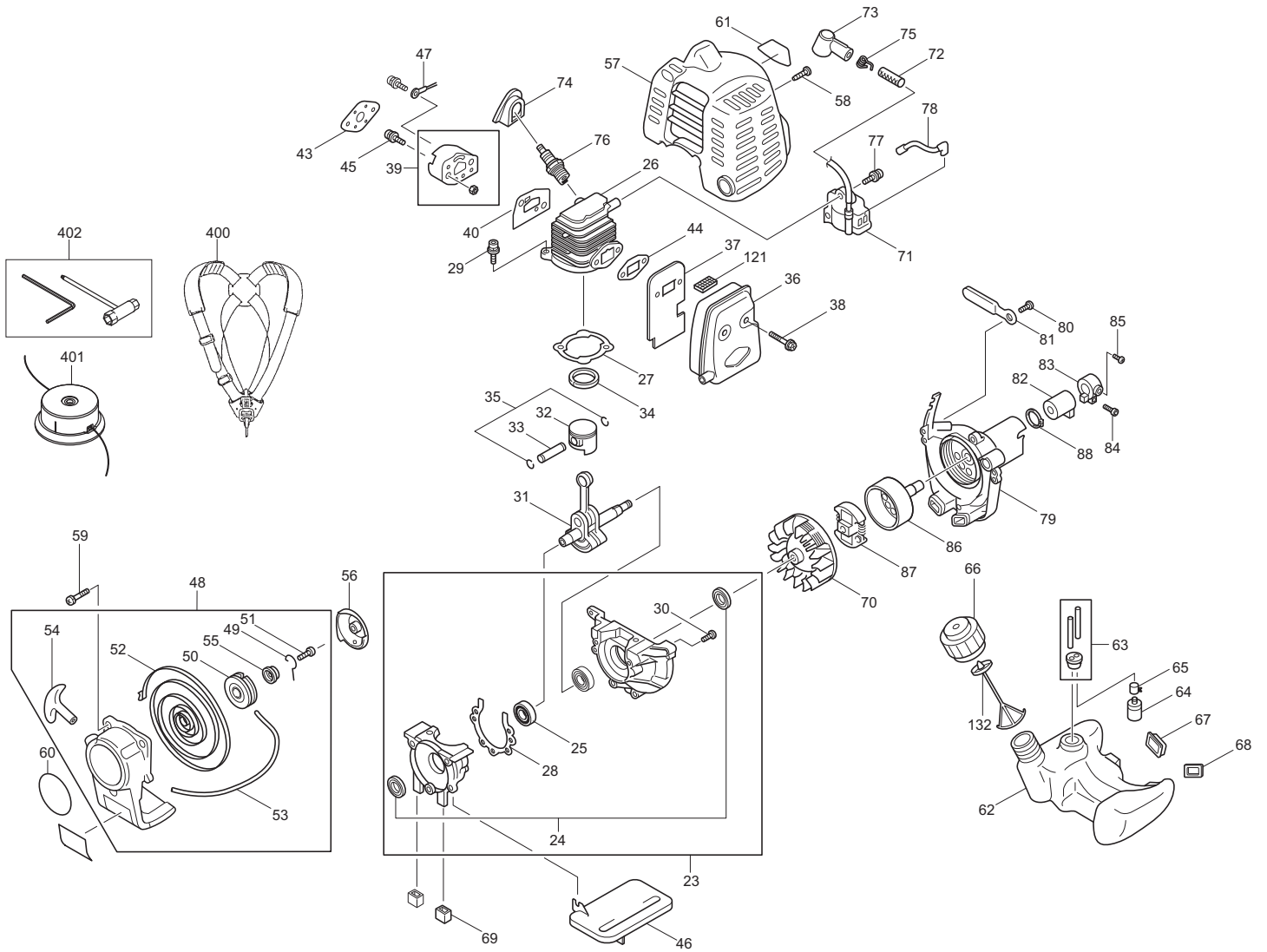

Seite / Page	Pos.	MS-20 C (USA)	Teil-Nr. Part No. No. de pièce No. de pieza	Hinweise Notes Renseign. Nota	Bezeichnung	Spezifikation Specification	Description	Désignation	Denominación
2	66	1	377 605 900		TANKVERSCHLUSS KPL.		FUEL TANK CAP COMPLETE	BOUCHON RÉSERVOIR CPL.	CIERRE DEPÓSITO CPL.
2	67	1	381 650 020		DÄMPFER		DAMPER	AMORTISSEUR	AMORTIGUADOR
2	68	1	381 650 030		DÄMPFER		DAMPER	AMORTISSEUR	AMORTIGUADOR
2	69	2	381 650 025		DÄMPFER		DAMPER	AMORTISSEUR	ANULAR
2	70	1	374 701 701		POLRAD		FLYWHEEL	VOLANT	VOLANTE
2	71	1	374 701 101		ZÜNDSPULE		IGNITION COIL	BOBINE D' ALLUMAGE	BOBINA DE ENCENDIDO
2	72	1	374 111 993		ISOLIERSCHLAUCH		HOSE	TUYAU	TUBO
2	73	1	100 143 060		ZÜNDKERZENSTECKER		SPARK PLUG CAP	FICHE DE BOUGIE	TAPA DE BUJÍA
2	74	1	388 750 010		ABDECKUNG		PLUG CAP COVER	COUVERCLE	TAPA
2	75	1	377 400 993		FEDER		PLUG CAP SPRING	RESSORT CAPUCHON DE FICHE	MUELLE TAPA DEL ENCHUFE
2	76	1	374 014 981		ZÜNDKERZE		SPARK PLUG	BOUGIE	BUJÍA
2	77	1	367 004 992		SCHRAUBE KPL.	M4X20	SCREW ASSY.	VIS	TORNILLO
2	78	1	367 701 800		KABEL KPL.		WIRE COMPLETE	CÂBLE COMPLET	CABLE CPL
2	79	1	374 100 600		KUPPLUNGSGEHÄUSE	RED	CLUTCH CASE	CARTER D' EMBRAYAGE	CÁRTER DE EMBRAGUE
2	80	3	381 005 998		SCHNEIDSCHRAUBE	M5X20	TAPPING SCREW	VIS TARAUEUSE	TORNILLO DE ROSCA CORTANTE
2	81	1	374 605 998		KLEMMSCHELLE		CLAMP	COLLIER DE SERRAGE	ABRAZADERA DE SUJECIÓN
2	82	1	374 150 020		DÄMPFER		PIPE DAMPER	AMORTISSEUR	AMORTIGUADOR
2	83	1	374 150 130		HALTER		PIPE BRACKET	SUPPORT	SOPORTE
2	84	1	383 905 988		SCHRAUBE	M5X25	SCREW	VIS	TORNILLO
2	85	1	374 905 985	2002 =>	INNEN-6KT-SCHRAUBE	M5X14	SOCKET HEAD BOLT	VIS	TORNILLO
2	85	1	377 150 050	=> 2001	BLECHSCHRAUBE		TAPPING SCREW	VIS TARAUEUSE	TORNILLO DE ROSCA CORTANTE
2	86	1	383 200 100		KUPPLUNGSTROMMEL KPL.		CLUTCH DRUM COMPLETE	TAMBOUR CPL.	TAMBOR CPL.
2	87	1	381 200 200		KUPPLUNG KPL.		CLUTCH ASSY.	EMBRAYAGE CPL.	EMBRAGUE CPL.
2	88	1	374 151 000		SPRENGRING	10	CLIP	ANNEAU RESSORT	ANILLO ELÁSTICO
2	121	1	374 300 105		FUNKENSCHUTZSIEBEL		SPARK ARRESTER SCREEN	TAMIS	TAMIZ
2	132	1	374 606 700		VERLIERSICHERUNG		STRAP	CHAINE DE SECURITE	SEGURO CONTRA PERDIDAS
2	400	1	387 260 100		DOPPEL-SCHULTER GURT		DOUBLE SHOULDER HARN.	BRETTE DOUBLE	HARNES DE HOMBROS
2	401	1	374 601 430		FADENKOPF		NYLON CUTTING HEAD (BUMP& FEED)	TETE A FILS	CABEZA CORT
2	402	1	381 900 600		WERKZEUGSATZ		TOOL KIT	OUTILS CPL	HERRAMIENTAS CPL.

MS-20 C (USA) , MS-22 C (USA)

3

Hauptrohr, Griff, Schutzhaube, Getriebe
Pipe, handle, protector, bevel gear
Tubo, poignée, capot de protection, engrenage
Tubo, mango, cubierta protectora, engranaje

DOLMAR
A member of the *Makita* Group

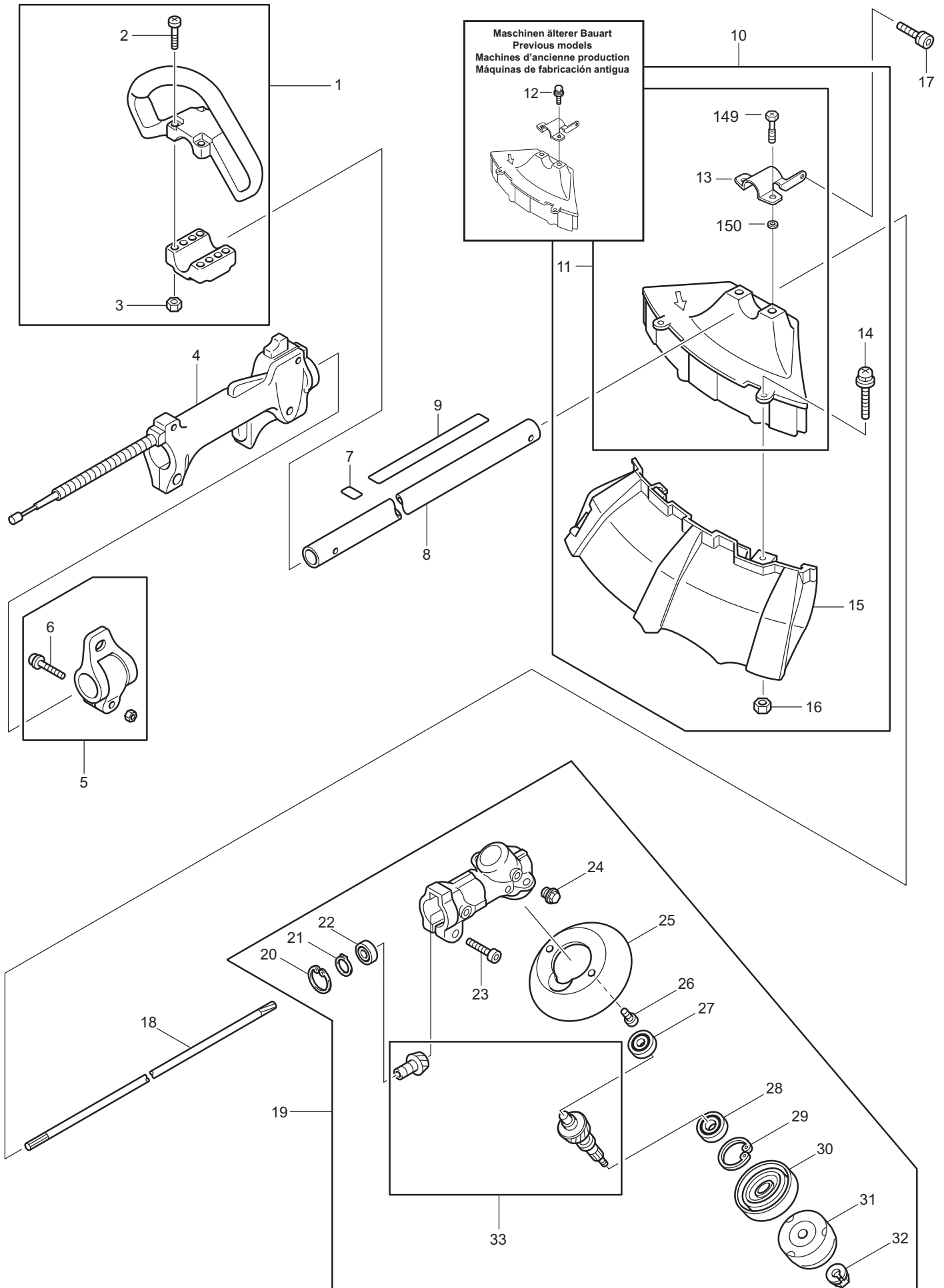

MS-20 C (USA) , MS-22 C (USA)

3

Hauptrohr, Griff, Schutzhaube, Getriebe
 Pipe, handle, protector, bevel gear
 Tube, poignée, capot de protection, engrenage
 Tubo, mango, cubierta protectora, engranaje

DOLMAR

 A member of the Makita Group

Seite / Page	Pos.	MS-22 C (USA)	Teil-Nr. Part No. No. de pièce No. de pieza	Hinweise Notes Renseign. Nota	Bezeichnung	Spezifikation Specification	Description	Désignation	Denominación
3	A01	1	381 900 600	STANDARD EQUIPMENT NO PICT.	WERKZEUGSATZ		TOOL KIT	OUTILS CPL	HERRAMIENTAS CPL.
3	A02	1	374 700 400	STANDARD EQUIPMENT NO PICT.	SCHULTERGURT KPL.		SHOULDER HARNESS	COURROIE D'ÉPAULE	BANDOLERA
3	A03	1	381 224 263	STANDARD EQUIPMENT NO PICT.	FADENKOPF	ULTRA-AUTO-4	NYLON CUTTING HEAD	TETE A 2 FILS	CABEZA 2 CORT
3	A03.1	1	381 224 350		ADAPTER		ADAPTOR, LEFT THREAD	ADAPTEUR GAUCHE	ADAPTADOR IZQUIERDA
3	A03.2	2	381 224 330		FADENBUCHSE		THREAD BUSH	DOUILLE DE FIL	BUJE DE HILO
3	A03.3	1	381 224 310		SPULE		SPOOL FOR LINE	BOUBINE DE FIL	BOBINA CON HILO
3	A03.4	1	381 224 390		DECKEL		COVER	CAPOT	CUBIERTA
3	A03.5	1	381 224 320		KNOPF		BUTTON	BOUCHON	BOTON
3	A04	1	940 804 000	STANDARD EQUIPMENT NO PICT.	6KT-STIFTSCHLÜSSEL		HEX. WRENCH	CLÉ MÂLE COUDÉE	LLAVE HEXAGONAL
3	1	1	374 401 700		HANDGRIFF SATZ	INC. 2,3	HANDLE, SET	POIGNÉE, JEU	MANGO, JUEGO
3	2	4	374 401 603		SCHRAUBE		SCREW	VIS	TORNILLO
3	3	4	381 270 500		MUTTER	M5	NUT	ECROU	TUERCA
3	4	1	374 502 100		BEDIENUNGSHAND GRIFF KPL.		CONTROL LEVER CPL.	LEVIER DE RÉGLAGE CPL.	BOTÓN DE MANDO CPL.
3	5	1	367 195 143		TRAGEGURTAUFNAHME SATZ		HANGER SET	ATTACHE DE BRETTELLE JEU	SUJECIÓN JUEGO
3	6	1	381 005 936		SCHRAUBE MIT SCHEIBE		SCREW & WASHER ASS'Y	VIS AVEC RONDELLE	TORNILLO CON ARANDELA
3	7	1	367 951 470		SICHERHEITSAUFKLEBER		CAUTION LABEL	PLAQUE	CALCOMANIA
3	8	1	374 100 100		SCHAFTROHR KPL.		SHAFT PIPE COMPLETE	TUBE PRINCIPAL CPL.	TUBO PRINCIPAL CPL.
3	9	1	374 952 130		SICHERHEITSAUFKLEBER		CAUTION LABEL	PLAQUE	CALCOMANIA
3	10	1	374 801 400	STANDARD EQUIPMENT	SCHUTZHAUBE KPL.		PROTECTION HOOD ASSY	CAPOT DE PROTECTION CPL.	CUBIERTA PROTECTORA CPL.
3	11	1	367 806 100	STANDARD EQUIPMENT	SCHUTZHAUBE FÜR METALLBLATT		PROTECTION HOOD	CAPOT DE PROTECTION	CUBIERTA PROTECTORA
3	12	2	381 006 979		BOLZEN	M6X30	BOLT	BOULON	BULÓN
3	13	1	382 850 820		SCHELLE		PROTECTOR CLAMP	COLLIER	ABRAZADERA
3	14	2	381 005 938		SCHRAUBE KPL.		SCREW ASSEMBLY	VIS CPL.	TORNILLO CPL.
3	15	1	367 800 800		SCHUTZHAUBE FÜR FADENKOPF		PROTECTION HOOD	CAPOT DE PROTECTION	CUBIERTA PROTECTORA
3	16	2	367 180 500		MUTTER	M5	NUT	ECROU	TUERCA
3	17	1	367 905 949		SCHRAUBE	M5X14 (W,SW)	S. H. BOLT	VIS	TORNILLO
3	18	1	367 150 630		WELLE		SHAFT	ARBRE	ÁRBOL
3	19	1	382 300 600		GETRIEBEGEHÄUSE KPL.		GEAR CASE ASSY	CARTER D'ENGRENAGES CPL.	CAJA DE ENGRANAJES CPL.
3	20	1	381 142 400		SICHERUNGSRING		INNER SNAP RING	CIRCLIP	ANILLO SEGURIDAD
3	21	1	374 300 612		SPRENGRING		OUTER SNAP RING	ANNEAU RESSORT	ANILLO ELÁSTICO
3	22	1	381 250 030		KUGELLAGER	#609ZZ	BALL BEARING	ROULEMENT A BILLES	RODAMIENTO DE BOLAS
3	23	1	367 905 989		SCHRAUBE	M5X25	S. H. BOLT	VIS	TORNILLO
3	24	1	367 301 101		BOLZEN	M6X9	BOLT	BOULON	BULÓN
3	25	1	381 850 020		SCHUTZVORRICHTUNG		GUARD	CAPOT DE PROTECTION	TAPA PROTECTORA
3	26	2	381 005 939		SCHRAUBE KPL.		SCREW ASSEMBLY	VIS CPL.	TORNILLO CPL.
3	27	1	367 006 999		KUGELLAGER	626ZZ	BALL BEARING	ROULEMENT A BILLES	RODAMIENTO DE BOLAS

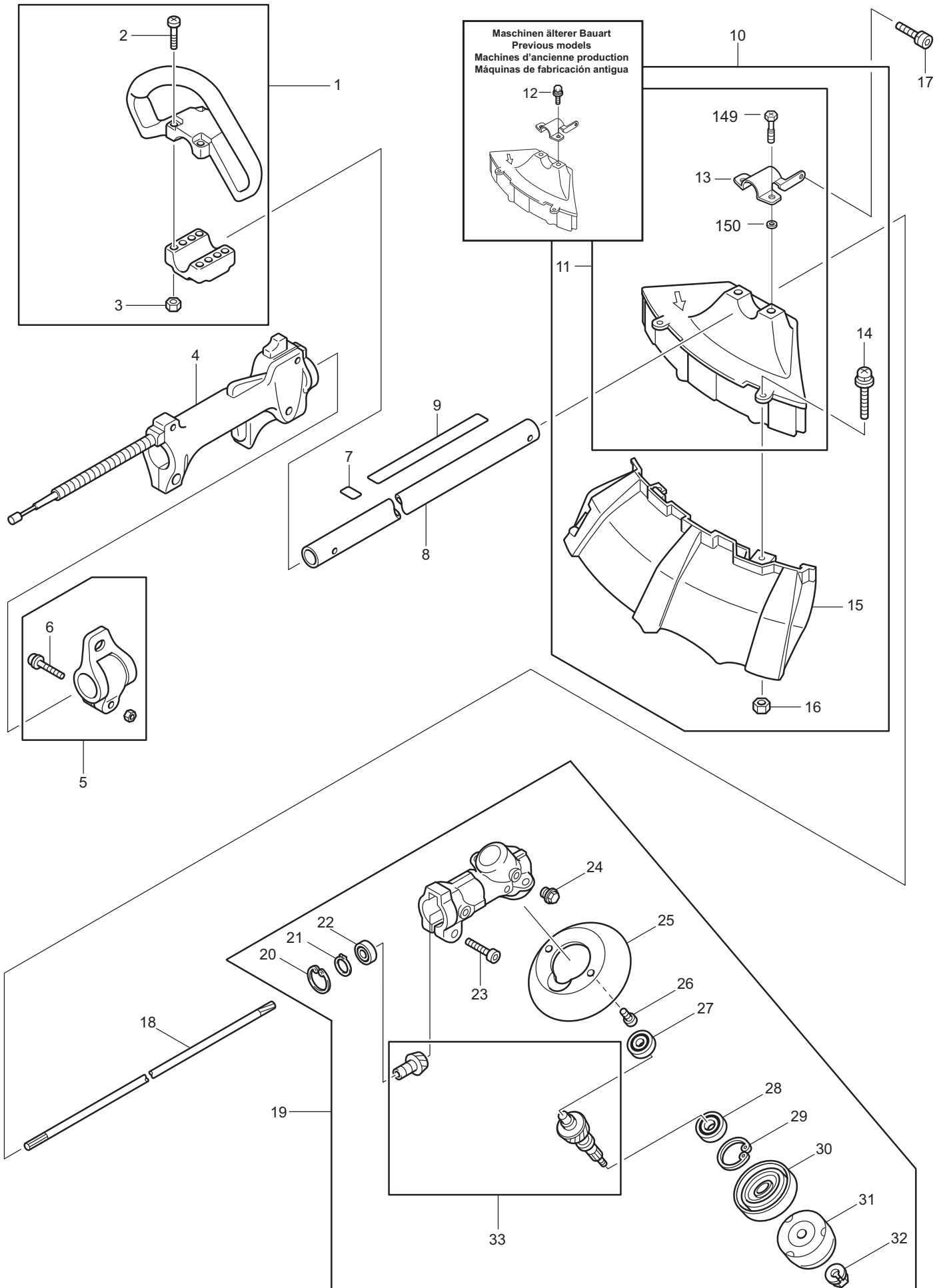

MS-20 C (USA) , MS-22 C (USA)

3

Hauptrohr, Griff, Schutzhaube, Getriebe
 Pipe, handle, protector, bevel gear
 Tube, poignée, capot de protection, engrenage
 Tubo, mango, cubierta protectora, engranaje

DOLMAR

 A member of the *Makita* Group

Seite / Page	Pos.	MS-22 C (USA)	Teil-Nr. Part No. No. de pièce No. de pieza	Hinweise Notes Renseign. Nota	Bezeichnung	Spezifikation Specification	Description	Désignation	Denominación
3	28	1	388 010 991		KUGELLAGER	6000DDU	BALL BEARING	ROULEMENT A BILLES	RODAMIENTO DE BOLAS
3	29	1	381 142 600		SICHERUNGSRING		INNER SNAP RING	CIRCLIP INTERIEUR	ARANDELA DE SEGURIDAD INTERIOR
3	30	1	367 850 160		AUFNAHMESCHEIBE		RECEIVE WASHER	DISQUE DE SUPPORT	DISCO DE SUJECIÓN
3	31	1	381 800 300		DRUCKSCHEIBE	Z6	CLAMP WASHER	JEU DISQUE DE PRESSION CPL.	JUEGO DISCO DE PRESION
3	32	1	367 850 500		MUTTER MIT FEDERSCHEIBE		NUT WITH SPRING WASHER	ECROU AVEC RONDELLE A RESSORT	TUERCA CON ARANDELA ELÁSTICO
3	33	1	388 300 800		GETRIEBERÄDER KPL.		CUTTER SHAFT SET	ROUES D'ENGRENAGES CPL.	RUEDAS DE ENGRANAJEW CPL.
3	149	2	381 006 977		KREUZSCHLITZSCH RAUBE	M6x23	CROSS RECESS BOLT	VIS	TORNILLO
3	150	2	367 413 143		SCHEIBE		WASHER	RONDELLE	ARANDELA

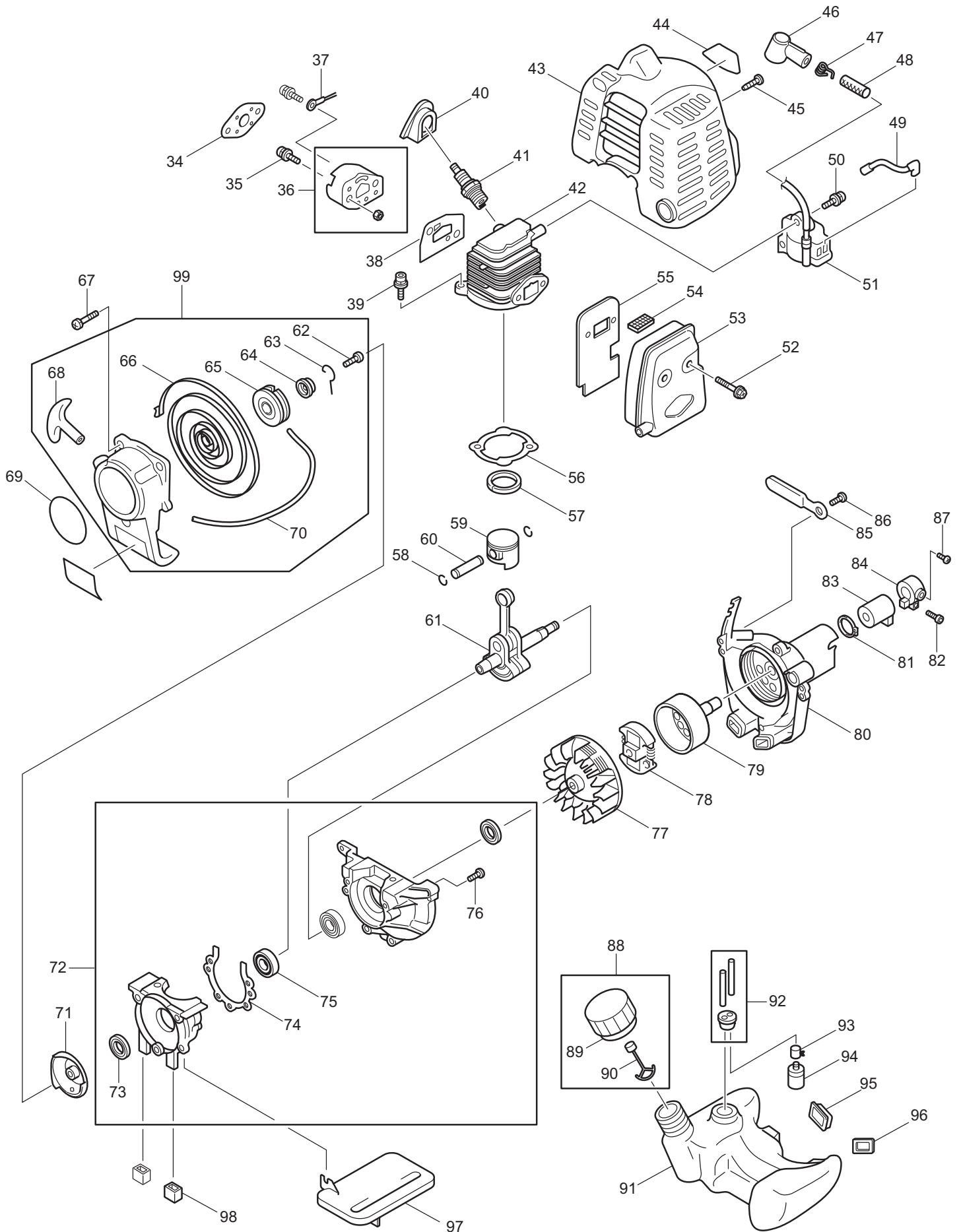

MS-20 C (USA) , MS-22 C (USA)

4

Motor, Anwerfvorrichtung, Kupplung, Kraftstofftank
 Engine, starter, clutch, fuel tank
 Moteur, dispositif de démarrage, embrayage, réservoir d'essence
 Motor, dispositivo de arranque, embrague, depósito de combustible

DOLMAR

 A member of the *Hakita* Group

Seite / Page	Pos.	MS-22 C (USA)	Teil-Nr. Part No. No. de pièce No. de pieza	Hinweise Notes Renseign. Nota	Bezeichnung	Spezifikation Specification	Description	Désignation	Denominación
4	34	1	381 350 280		DICHTUNG		GASKET	JOINT	JUNTA
4	35	2	388 005 950		SCHRAUBE	M5X25	SCREW	VIS	TORNILLO
4	36	1	381 301 400		ZWISCHENFLANSCH		INSULATOR	BRIDE INTERMEDIAIRE	BRIDA INTERMEDIA
4	37	1	381 550 020		KABEL		WIRE	CÂBLE	CABLE
4	38	1	377 350 050		DICHTUNG F. ZWISCHENFLANSCH		INSULATOR GASKET	JOINT	JUNTA
4	39	2	382 905 973		SCHRAUBE	M5X20 W/W&SW	SOCKET HEAD BOLT	VIS	TORNILLO
4	40	1	388 750 010		ABDECKUNG		PLUG CAP COVER	COUVERCLE	TAPA
4	41	1	374 014 971		ZÜNDKERZE		SPARK PLUG	BOUGIE	BUJÍA
4	42	1	381 150 090		ZYLINDER		CYLINDER	CYLINDRE	CYLINDRO
4	43	1	381 550 310		ZYLINDERHAUBE		CYLINDER COVER	CAPOT DE CYLINDRE	TAPA PARA CYLINDRO
4	44	1	381 950 810		SCHILD	DOLMAR	TRADE MARK LABEL "DOLMAR"	PLAQUE	PLACA
4	45	1	388 005 979		SCHNEIDSCHRAUBE	5X14	TAPPING SCREW	VIS DE COUPE	TORNILLO DE ENTALLAR
4	46	1	388 500 987		ZÜNDKERZENSTECKER		PLUG CAP	COSSE DE BOUGIE	TAPÓN
4	47	1	377 400 993		FEDER		PLUG CAP SPRING	RESSORT CAPUCHON DE FICHE	MUELLE TAPA DEL ENCHUFE
4	48	1	374 108 995		ROHR		TUBE	TUBE	TUBO
4	49	1	374 701 800		KABEL		WIRE	CÂBLE	CABLE
4	50	2	381 004 977		SCHRAUBE KPL.	M4X16(W,SW)	SCREW ASSY	VIS CPL.	TORNILLO CPL.
4	51	1	374 701 101		ZÜNDSPULE		IGNITION COIL	BOBINE D' ALLUMAGE	BOBINA DE ENCENDIDO
4	52	1	367 905 952		SCHRAUBE	M5X40	SOCKET HEAD BOLT	VIS	TORNILLO
4	53	1	368 300 100		SCHALLDÄMPFER KPL.		EXHAUST MUFFLER	POT D' ÉCHAPPEMENT	SILENCIADOR
4	54	1	374 300 105		FUNKENSCHUTZSIEB		SPARK ARRESTER SCREEN	TAMIS	TAMIZ
4	55	1	383 350 000		ISOLATOR	INC. 54	INSULATOR, MUFFLER	ISOLATEUR	AISLADOR
4	56	1	382 150 030		DICHTUNG		CYLINDER GASKET	JOINT	JUNTA
4	57	1	374 250 050		KOLBENRING		PISTON RING	SEGMENT DE PISTON	SEGMENT DE PISTON
4	58	2	388 508 997		SPRENGRING		CLIP	ANNEAU RESSORT	ANILLO ELÁSTICO
4	59	1	374 250 170		KOLBEN		PISTON	PISTON	PISTÓN
4	60	1	367 250 050		KOLBENBOLZEN		PISTON PIN	AXE DE PISTON	BULÓN DEL PISTÓN
4	61	1	388 200 100		KURBELWELLE KPL.		CRANKSHAFT ASSY.	VILEBREQUIN CPL. CPL.	CIGÜEÑAL CPL.
4	62	1	367 266 585		BLECHSCHRAUBE	5X12	TAPPING SCREW	VIS TARAUDEUSE	TORNILLO DE ROSCA CORTANTE
4	63	1	367 500 210		MITNEHMERBÜGEL		SWING ARM	ETRIER D'ENTRAÎNEMENT	BRAZO OSCILANTE
4	64	1	367 500 211		AUFNAHME F. MITNEHMERBÜGEL		COLLAR	LOGEMENT POU ETRIER	ANILLO DE RETENCIÓN
4	65	1	383 500 203		SEILTROMMEL		REEL	TAMBOUR DE CÂBLE	TAMBOR PARA CUERDA
4	66	1	381 500 205		RÜCKHOLFEDER		SPIRAL SPRING	RESSORT DE RAPPEL	RESORTE RETENCION
4	67	3	381 004 977		SCHRAUBE KPL.	M4X16(W,SW)	SCREW ASSY	VIS CPL.	TORNILLO CPL.
4	68	1	388 500 402		GRIFF		HANDLE CPL.	POIGNÉE	EMPUÑADURA
4	69	1	374 952 050		SCHILD		MODEL LABEL	PLAQUE	CALCOMANIA
4	70	1	388 501 602		ANWERFSEIL	Ø 3,5 x 850 mm	STARTER ROPE	CORDE DE LANCEUR	CUERDA DE ARRANQUE
4	71	1	367 550 000		STARTERRAD		PULLEY	ROUE DÉMARREUR	RUEDA DE ARRANQUE
4	72	1	383 100 400		KURBELGEHÄUSE KPL.		CRANKCASE CPL.	CARTER-VILEBREQUIN CPL.	CÁRTER CIGÜEÑAL CPL.
4	73	2	374 010 998		RADIALDICHTRING		OIL SEAL	JOINT RADIAL	JUNTA RADIAL
4	74	1	318 150 040		DICHTUNG		CRANKCASE GASKET	JOINT	JUNTA

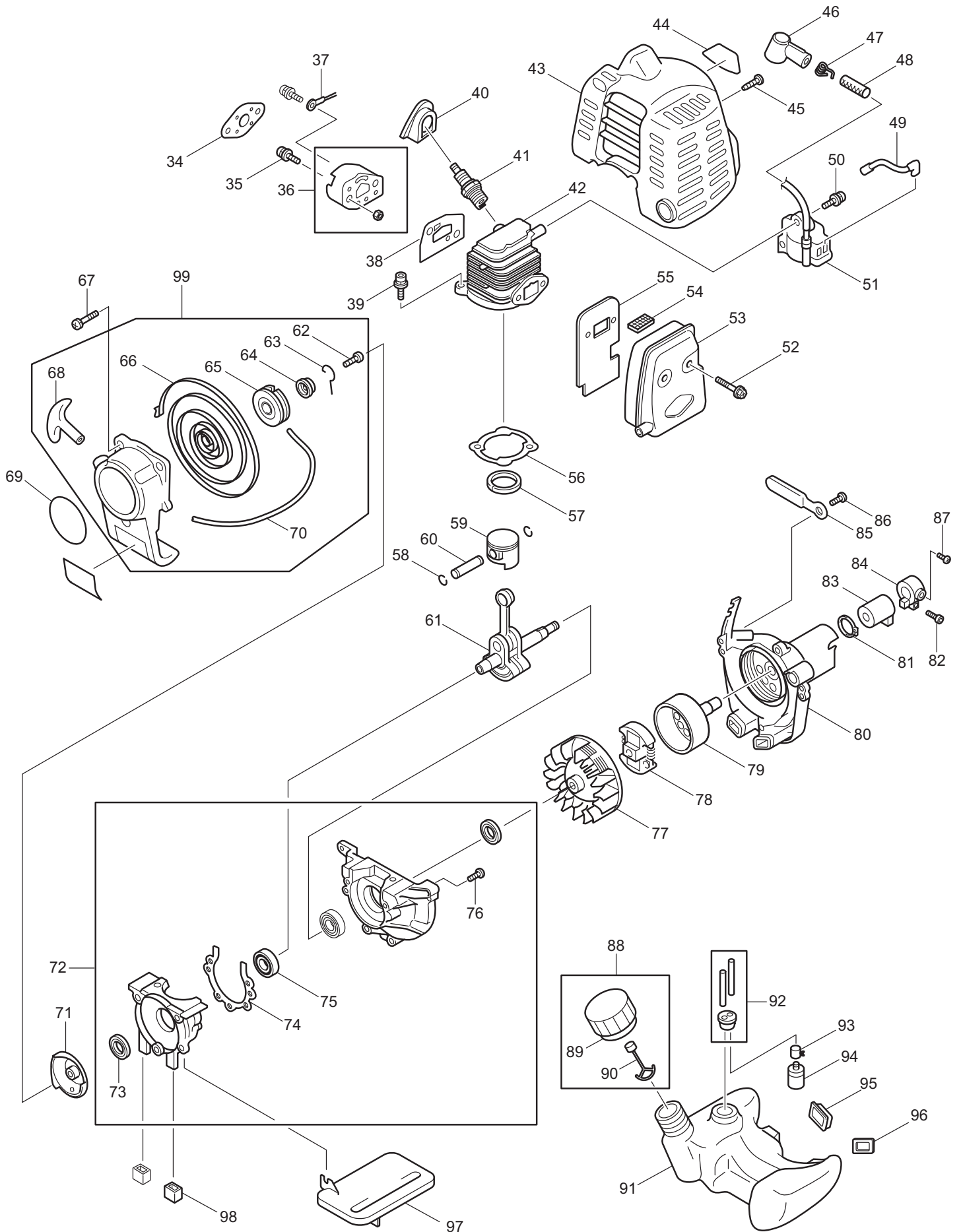

MS-20 C (USA) , MS-22 C (USA)

4

Motor, Anwerfvorrichtung, Kupplung, Kraftstofftank
 Engine, starter, clutch, fuel tank
 Moteur, dispositif de démarrage, embrayage, réservoir d'essence
 Motor, dispositivo de arranque, embrague, depósito de combustible

DOLMAR

 A member of the *Hakita* Group

Seite / Page	Pos.	MS-22 C (USA)	Teil-Nr. Part No. No. de pièce No. de pieza	Hinweise Notes Renseign. Nota	Bezeichnung	Spezifikation Specification	Description	Désignation	Denominación
4	75	2	381 010 998		KUGELLAGER	6000	BALL BEARING	ROULEMENT Á BILLES	RODAMIENTO DE BOLAS
4	76	3	388 005 952		SCHRAUBE	M5X25	SCREW	VIS CPL.	TORNILLO CPL.
4	77	1	374 701 701		POLRAD		FLYWHEEL	VOLANT	VOLANTE
4	78	1	381 200 200		KUPPLUNG KPL.		CLUTCH ASSY.	EMBRAYAGE CPL.	EMBRAGUE CPL.
4	79	1	383 200 100		KUPPLUNGSTROMMEL KPL.		CLUTCH DRUM COMPLETE	TAMBOUR CPL.	TAMBOR CPL.
4	83	1	374 150 020		DÄMPFER		PIPE DAMPER	AMORTISSEUR	AMORTIGUADOR
4	84	1	374 150 130		HALTER		PIPE BRACKET	SUPPORT	SOPORTE
4	85	1	374 605 998		KLEMMSCHELLE		CLAMP	COLLIER DE SERRAGE	ABRAZADERA DE SUJECIÓN
4	86	3	374 005 978		SCHRAUBE	M5X20	TAPPING SCREW	VIS	TORNILLO
4	87	1	374 905 985		INNEN-6KT-SCHRAUBE	M5X14	SOCKET HEAD BOLT	VIS	TORNILLO
4	88	1	377 605 900		TANKVERSCHLUSS KPL.		FUEL TANK CAP COMPLETE	BOUCHON RÉSERVOIR CPL.	CIERRE DEPÓSITO CPL.
4	89	1	377 605 900		TANKVERSCHLUSS KPL.		FUEL TANK CAP COMPLETE	BOUCHON RÉSERVOIR CPL.	CIERRE DEPÓSITO CPL.
4	90	1	374 606 700		VERLIERSICHERUNG		STRAP	CHAINE DE SECURITE	SEGURO CONTRA PERDIDAS
4	91	1	382 650 000		KRAFTSTOFFTANK		FUEL TANK	RÉSERVOIR D'ESSENCE	DEPÓSITO DE COMBUSTIBLE
4	92	1	374 115 992		SCHLAUCH KPL.		TUBE	TUBE	TUBO
4	93	1	381 105 999		SCHLAUCHKLEMME		HOSE CLAMP	COLLIER	ABRAZADERA
4	94	1	320 163 447		BENZINFILTER		GASOLIN FILTER	FILTRE D'ESSENCE	FILTRO DE GASOLINA
4	95	1	381 650 020		DÄMPFER		DAMPER	AMORTISSEUR	AMORTIGUADOR
4	96	1	381 650 030		DÄMPFER		DAMPER	AMORTISSEUR	AMORTIGUADOR
4	97	1	383 350 010		PLATTE		PLATE	PLAQUE	PLANCHA
4	98	2	381 650 025		DÄMPFER		DAMPER	AMORTISSEUR	ANULAR
4	80	1	374 100 600		KUPPLUNGSGEHÄUSE	RED	CLUTCH CASE	CARTER D'EMBRAYAGE	CÁRTER DE EMBRAGUE
4	81	1	374 151 000		SPRENGRING	10	CLIP	ANNEAU RESSORT	ANILLO ELÁSTICO
4	82	1	383 905 988		SCHRAUBE	M5X25	SCREW	VIS	TORNILLO
4	99	1	381 500 900		STARTVORRICHTUNG		REWIND STARTER	DISPOS. DE DÉMARRAGE	DISPOS. DE ARRANQUE

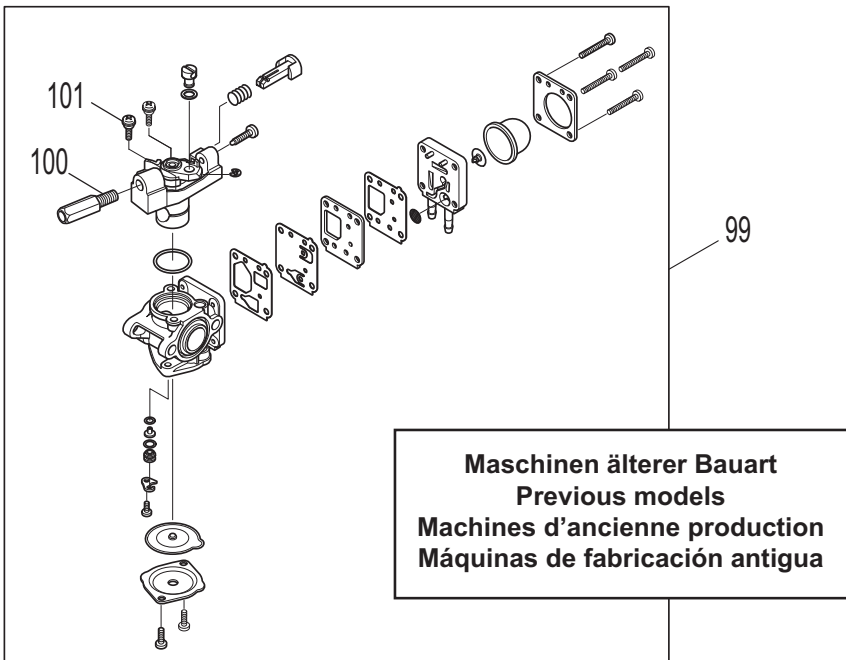
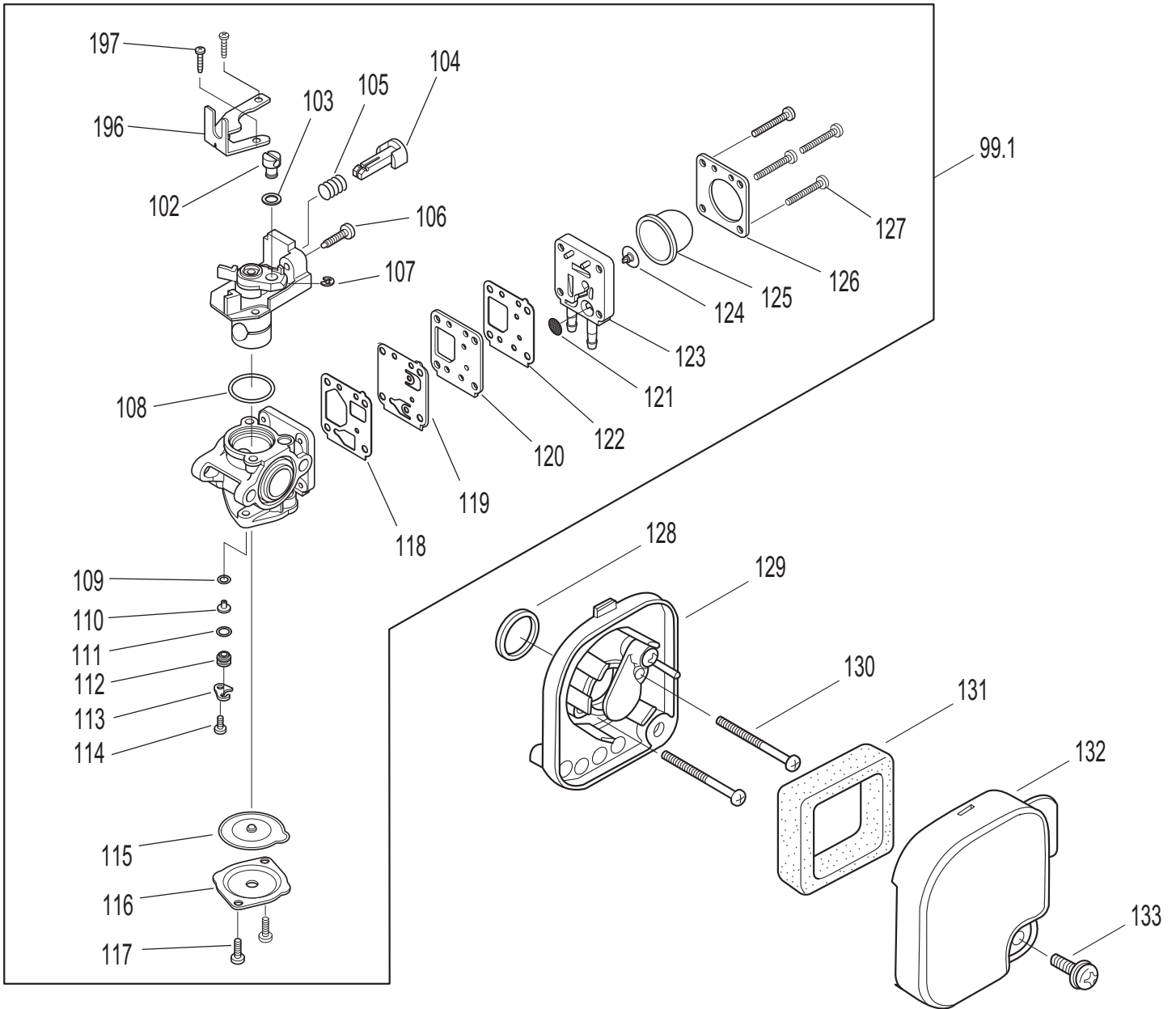

MS-20 C (USA) , MS-22 C (USA)

5

Vergaser, Luftfilter
Carburetor, air cleaner
Carburateur, filtre à air
Carburador, filtro de aire**DOLMAR**
A member of the *Makita* Group

Seite / Page	Pos.	MS-22 C (USA)	Teil-Nr. Part No. No. de pièce No. de pieza	Hinweise Notes Renseign. Nota	Bezeichnung	Spezifikation Specification	Description	Désignation	Denominación
5	99	1	374 603 600		VERGASER	TZ9V-2G, => 2009-10	CARBURETOR	CARBURATEUR	CARBURADOR
5	99.1	1	374 604 300		VERGASER	TZ9V-2L, 2009-11 =>	CARBURETOR	CARBURATEUR	CARBURADOR
5	100	1	374 601 924		EINSTELLSCHRAUBE	=> 2009-10	ADJUST SCREW	VIS DE REGLAGE	TORNILLO DE AJUSTE
5	101	2	374 601 931		SCHRAUBE	=> 2009-10	SCREW	VIS	TORNILLO
5	102	1	374 601 945		NOCKEN		SWIVEL	CAME	LEVA
5	103	1	374 601 946		SCHEIBE		WASHER	RONDELLE	ARANDELA
5	104	1	374 603 601		HEBEL		STARTER LEVER	LEVIER	PALANCA
5	105	1	374 603 602		FEDER		SPRING	RESSORT	MUELLE
5	106	1	374 601 925		SCHRAUBE		SLOW STOP SCREW	VIS DE BUTÉE DE RALENTI	TORNILLO DE TOPE
5	107	1	374 601 951		SICHERUNGSSCHRAUBE		SAFETY WASHER	RONDELLE SÉCURITÉ	ARANDELA SEGURIDAD
5	108	1	374 601 922		O-RING		O-RING	BAGUE JOINT	ANILLO DE GUARNICIÓN
5	109	1	374 601 915		O-RING		O-RING	BAGUE JOINT	ANILLO DE GUARNICIÓN
5	110	1	381 603 201		HAUPTDÜSE		MAIN JET	TUYÈRE PRINCIPALE	TOBERA PRINCIPAL
5	111	1	374 601 941		O-RING		O-RING	BAGUE JOINT	ANILLO DE GUARNICIÓN
5	112	1	374 601 936		VENTIL KPL.		CHECK VALVE ASSY.	SOUPAPE CPL.	VÁLVULA CPL.
5	113	1	374 601 942		FÜHRUNG		GUIDE PLATE	GUIDE	GUÍA
5	114	1	374 601 943		SCHRAUBE		SCREW	VIS	TORNILLO
5	115	1	374 601 904		MEMBRANE		DIAPHRAGM ASSY.	MEMBRANE DE COMM. JEU	MEMBRANAS DE MANDO JUEGO
5	116	1	374 601 905		ABDECKUNG		DIAPHRAGM COVER	COUVERCLE	CUBIERTA
5	117	2	374 601 906		SCHRAUBE		SCREW	VIS	TORNILLO
5	118	1	374 601 911		PUMPENDICHTUNG		PUMP GASKET	JOINT	JUNTA
5	119	1	374 601 912		PUMPENMEMBRAN		PUMP DIAPHRAGM	MEMBRANE DE POMPE	MEMBRANA DE LA BOMBA
5	120	1	374 601 935		PUMPENPLATTE		PUMP PLATE	PLAQUE	PLACA
5	121	1	374 601 933		FILTER		FILTER	FILTRE	FILTRO
5	122	1	374 601 913		DICHTUNG		PUMP PACKING	JOINT	JUNTA
5	123	1	374 601 934		ABDECKUNG		PUMP COVER	COUVERCLE	CUBIERTA
5	124	1	374 600 903		VENTIL		COMBINATION VALVE	SOUPAPE	VÁLVULA
5	125	1	374 600 904		PRIMER PUMPE		PRIMER PUMP	POMPE PRIMER	BOMBA PRIMER
5	126	1	374 601 932		PLATTE		PRIMING PUMP PLATE	PLAQUE	PLACA
5	127	4	374 601 914		SCHRAUBE		SCREW	VIS	TORNILLO
5	128	1	374 301 704		O-RING		O-RING	BAGUE JOINT	ANILLO DE GUARNICIÓN
5	129	1	374 301 801		GEHÄUSE		PLATE, AIR CLEANER ASSY	CARTER	CÁRTER
5	130	2	905 405 608		SCHRAUBE	M5x60	SCREW		
5	131	1	374 301 703		LUFTFILTER		AIR FILTER	FILTRE À AIR	FILTRO DE AIRE
5	132	1	374 301 802		LUFTFILTERGEHÄUSE		CASE, AIR CLEANER ASSY	CARTER	CÁRTER
5	133	1	381 005 948		SCHRAUBE KPL.	M5X14 W/W&SW	SCREW ASSY	VIS CPL.	TORNILLO CPL.
5	196	1	374 604 301		GASZUGHALTER	2009-11 =>	CABLE BRACKET	SUPPORT DU DISPOS. DE TIRAGE	TRACCIÓN BOWDEN, SOPORTE
5	197	2	374 604 302		SCHRAUBE	2009-11 =>	SCREW	VIS	TORNILLO

4.1

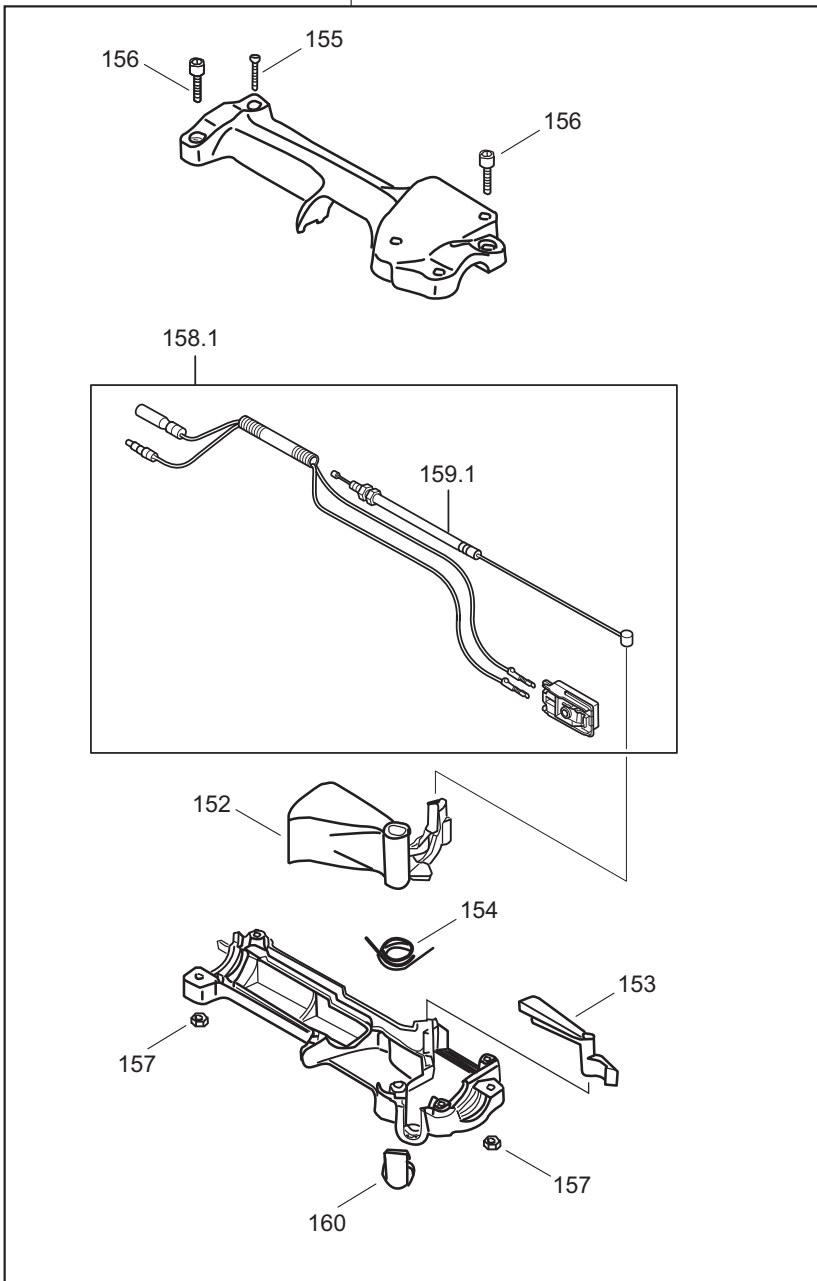

4

Maschinen älterer Bauart
Previous models
Machines d'ancienne production
Máquinas de fabricación antigua

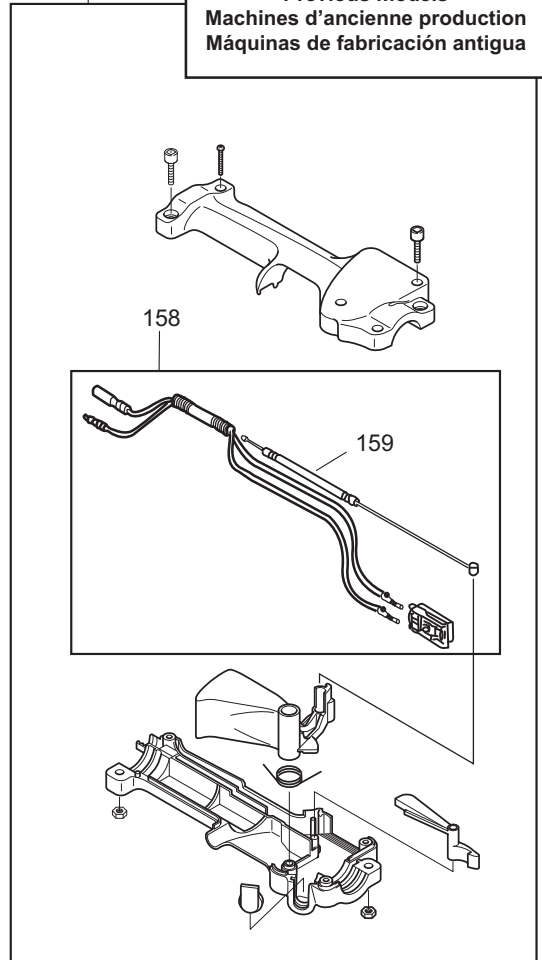

Seite / Page	Pos.	MS-22 C (USA)	Teil-Nr. Part No. No. de pièce No. de pieza	Hinweise Notes Renseign. Nota	Bezeichnung	Spezifikation Specification	Description	Désignation	Denominación
6	4	1	374 502 100		BEDIENUNGSHANDGRIF FF KPL.	=> 2009-10	CONTROL LEVER CPL.	LEVIER DE RÉGLAGE CPL.	BOTÓN DE MANDO CPL.
6	4.1	1	374 502 600		BEDIENUNGSHANDGRIF FF KPL.	2009-11 =>	CONTROL LEVER CPL.	LEVIER DE RÉGLAGE CPL.	BOTÓN DE MANDO CPL.
6	152	1	374 500 603		HEBEL		LEVER	LEVIER	PALANCA
6	153	1	367 502 306		GASHEBELSPERRE		LEVER	TOUCHE DE BLOCAGE	TECLA DE BLOQUEO
6	154	1	367 500 605		FEDER F. GASHEBEL		SPRING	RESSORT	MUELLE
6	155	4	367 500 606		SCHNEIDSCHRAUBE	M4X20	TAPPING SCREW	VIS DE COUPE	TORNILLO DE ROSCA CORTANTE
6	156	2	374 905 972		SCHRAUBE	M5X20	S. H. BOLT	VIS	TORNILLO
6	157	2	374 501 116		MUTTER		NUT	ECROU	TUERCA
6	158	1	374 502 101		KABELSATZ	=> 2009-10	SET OF WIRES	JEU DE CÂBLES	JUEGO DE CABLES
6	158. 1	1	374 502 601		GASZUG KPL.	2009-11 =>	WIRE SET	DISPOSITIF DE TIRAGE, CPL.	TRACCIÓN BOWDEN, CPL.
6	159	1	374 502 102		BOWDENZUG	=> 2009-10	CONTROL CABLE	CÂBLE BOWDEN	TRACCIÓN BOWDEN
6	159. 1	1	374 502 602		BOWDENZUG	2009-11 =>	CONTROL CABLE	CÂBLE BOWDEN	TRACCIÓN BOWDEN
6	160	1	381 500 615		KAPPE		TOP	CAPUCHON	CAPUCHA

- 1** Hauptrohr, Griff, Schutzhaube, Vergaser, Luftfilter
 Pipe, handle, protector, carburetor, air cleaner
 Tube, poignée, capot de protection, carburateur, filtre à air
 Tubo, mango, cubierta protectora, carburador, filtro de aire
- 2** Motor, Anwerfvorrichtung, Kupplung, Kraftstofftank, Zubehör
 Engine, starter, clutch, fuel tank, accessories
 Moteur, dispositif de démarrage, embrayage, réservoir d'essence,
 accessoires
 Motor, dispositivo de arranque, embrague, depósito de combustible, accesorios
- 3** Hauptrohr, Griff, Schutzhaube, Getriebe
 Pipe, handle, protector, bevel gear
 Tube, poignée, capot de protection, engrenage
 Tubo, mango, cubierta protectora, engranaje
- 4** Motor, Anwerfvorrichtung, Kupplung, Kraftstofftank
 Engine, starter, clutch, fuel tank
 Moteur, dispositif de démarrage, embrayage, réservoir d'essence
 Motor, dispositivo de arranque, embrague, depósito de combustible
- 5** Vergaser, Luftfilter
 Carburetor, air cleaner
 Carburateur, filtre à air
 Carburador, filtro de aire
- 6** MS-22 C Seite 6 Bedienungshandgriff
 Control lever
 Levier de commande
 Palanca de mando

	Zeichenerklärung	Key to symbols
=> 1999999 2000000 => 2003.04 => TI 2003/07 Acc. = { m Corr.	Produktion bis Serien-Nr. Neues Teil ab Serien-Nr. Neues Teil ab Jahr / Monat Siehe Technische Information Jahr / Nr. Zubehör (nicht im Lieferumfang) Keine Serienausführung, jedoch verwendbar Beinhaltet Positions-Nr. Meterware Druckfehlerberichtigung	Production to serial number New part from serial number New part from Year / Month See Technical Information Year / No. Accessories (not included in the delivery inventory) No standard execution, may be used Contains item number Sold by the meter Error correction
	Änderungen vorbehalten	Specifications subject to change without notice
	Légende	Explicación de símbolos
=> 1999999 2000000 => 2003.04 => TI 2003/07 Acc. = { m Corr.	Production jusqu'à n° de série Nouvelle pièce à partir du n° de série Nouvelle pièce à partir de année / mois Voir information technique année / n° Accessoires (non compris dans la livraison) Aucune exécut. en série, cependant utilisable contient n° de numéro Au mètre Rectification d'erreurs	Producción hasta N° de serie Pieza nueva a partir de N° de serie Pieza nueva a partir de año / mes Véase inform. técnico año / N° Accesorios (no incluido en la extensión del suministro) No es de serie, pero sirve Contiene pos N° Por metro Fe de erratas
	Changements sans préavis	Mejoras constructivas sin previo aviso